

ITS / STP Test Blocks & Plugs (4600 Series)

Reference Handbook

its-reference-en 25:7b8f23f68741



Copyright Notice

All information provided in this document is the property of **SECUCONTROL** .

SECUCONTROL grants its customers or potential customers the right to download, copy, store and print this document for the sole purpose of assisting them in the correct application of the products mentioned in this document.

All other uses of this document are expressly prohibited.

Intellectual Property Notice

This publication contains proprietary information under protection of the following (among others) patents: DE 10 2005 025 108, DE 10 2008 016 388, US 7,271,357 and US 7,884,597.

Contents Disclaimer

Although the information and recommendations in this document are presented in good faith and believed to be correct as of publication date, **SECUCONTROL** makes no representations as to the completeness or accuracy thereof. In no event shall **SECUCONTROL** be responsible for damages of any nature resulting from the use of or reliance upon the contents of this document.

Continuous Improvements

Products developed by **SECUCONTROL** are continuously improved. The information in this document may, therefore, be out of date.

Please make sure you have the latest release of this document before proceeding by checking its name and revision code. This information is printed on the front cover of this document, underneath the title. The latest release of this document can be downloaded from www.secucontrol.com/downloads. Alternatively, you may contact **SECUCONTROL** at any of the addresses provided on the rear cover of this document.

Contents

- 1 Introduction** **1**
 - The ITS / STP Test Block & Plug (4600 Series) 1
 - Key Features 1
 - Applicable Models 1
 - Unpacking 2
 - Part Number and Manufacturing Date Location 2
 - Safety Symbols 2
 - General Safety Instructions 2

- 2 Application** **5**
 - Schematic Symbols 5
 - Typical Connection Schematic 6

- 3 Installation** **7**
 - Panel Cutouts, Drilling Plans and Mounting 7
 - Wiring 9

- 4 Operation** **13**

- 5 Technical Specifications** **15**
 - Electrical 15
 - Mechanical 16
 - Dimensional Drawings 16

- 6 Accessories** **19**
 - Cases for STP Test Plugs 19
 - Individual Test Probes 19
 - Universal Test Probes Set 20
 - Handles for STP Test Plugs 20
 - Dust Covers for ITS Test Blocks 21

- 7 Spare Parts** **23**
 - Fitting Screws 23
 - Connection Screws 23

8 Ordering Information	25
Part Numbers for ITS Test Block (4600-Series)	25
Part Numbers for STP Test Plug(4600-Series)	26
Configuration Selection Chart	26

1 Introduction

The ITS / STP Test Block & Plug (4600 Series)

The ITS is a test block for interfacing substation devices (protection relays, fault recorders, revenue meters, ...) to the voltage and current transformers and to other equipment on the system side of a power grid.

STP is a test plug keyed to a particular configuration of ITS Test Blocks. Once inserted into the corresponding test block, the STP Test Plug isolates the substation devices from the system side equipment. Once the test plug is inserted the secondary injection can be performed.

Key Features

- Finger-safe test block and test plug increase safety during testing
- Test plugs are keyed to the corresponding test blocks and help eliminate the most common human errors during testing - and their sometimes costly consequences
- Built-in automatic operating sequence prevents spurious breaker operation
- Extremely low internal resistance ($< 2 \text{ m}\Omega$) helps reduce heat inside cabinets and panels and decreases the risk of saturation when using 1 A current transformers
- Available in 7, 10, 14 or 20 pole configurations
- Facilitates efficient, standardized testing procedures

Applicable Models

Information in this document applies to all 4600-series ITS Test Blocks and STP Test Plugs manufactured after February 2012.

Unpacking

Unpack the product carefully and make sure that all pertinent parts like mounting screws (and dust covers, if included) are put aside so they will not be lost.

Check the contents against the packing list. If any of the contents listed are missing, please contact **SECUCONTROL** immediately (see contact information at the rear cover of this manual).

Examine the product for any shipping damage. If the product is damaged, notify the shipping company without delay. Only the consignee (the person or company receiving the unit) can file a claim against the carrier for shipping damage.

Part Number and Manufacturing Date Location

Part number and manufacturing date are stated on a label on the right side of the test block or test plug.

Safety Symbols

The following symbols are located on different parts of the equipment and in this manual:



Paragraphs marked with this symbol contain information which, if not properly followed, may cause damage to the equipment and/or installation.



Paragraphs marked with this symbol contain information which, if not properly followed, may cause personal injury or even death.

General Safety Instructions

Installation and operation of the products described in this manual is only to be performed by personnel that has been trained or is knowledgeable in substation protection, automation and control.

This instruction manual is an integral part of the scope of delivery and provides basic instructions for installation and operation of the equipment here described. Shall additional information be needed, please contact **SECUCONTROL** at any of the addresses provided on the rear cover of this document.



Do not disassemble the test block or test plug. Correct alignment of internal parts is critical in order to provide insulation and arch-avoidance.

The warranty will be void if the test block or test plug is disassembled (or otherwise handled inappropriately). SecuControl does not assume responsibility for any dam-

ages arising out of mishandling of our products, including test blocks / test plugs that have been disassembled by parties other than SecuControl.



2 Application

Schematic Symbols

Following symbols are suggested in order to represent the ITS Test Block in schematic diagrams.

Symbol	Description
	Signal, Voltage (single pole)
	Current (2-pole, 4-pole)

Typical Connection Schematic

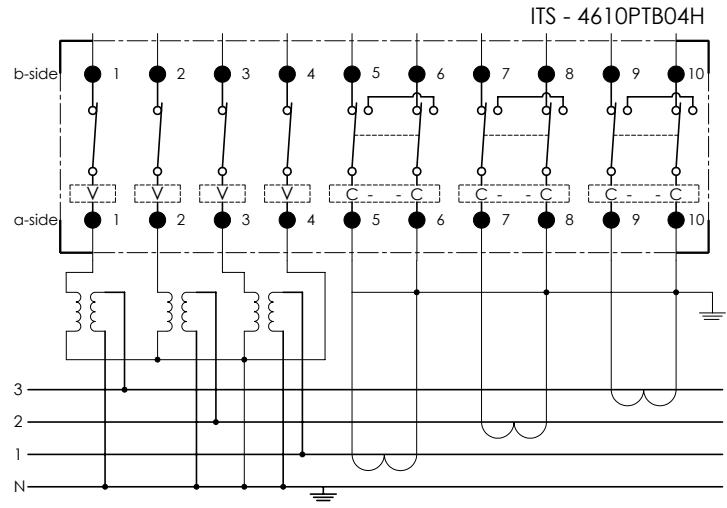

3 Installation

Panel Cutouts, Drilling Plans and Mounting

The cutout for the ITS Test Block must be done using the cutout plan for the correct size ITS, shown below. The thickness of the panel sheet must not exceed 3 millimeters (0.118 inches). The threaded holes M4 in the panel cutout diagram are only required when using ITS dust covers which are an additional option.

Use the provided 4 pc. M4x10 button head screws with hexagon socket (2.5mm) to fix the ITS Test Block in the panel cutout. The test block has to be inserted from the back side and screwed from the front side.

7-pole Models

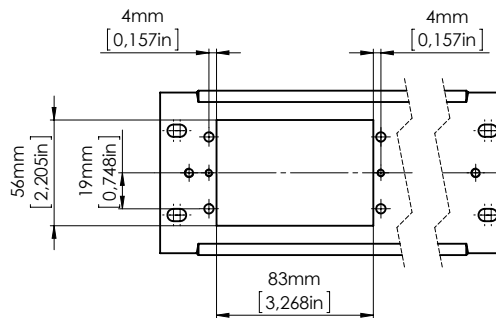

3. INSTALLATION

10-pole Models

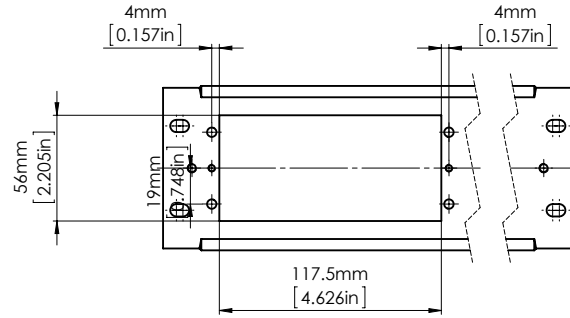

14-pole Models

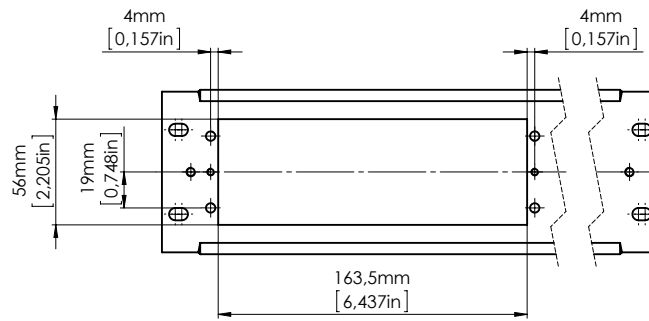

20-pole Models

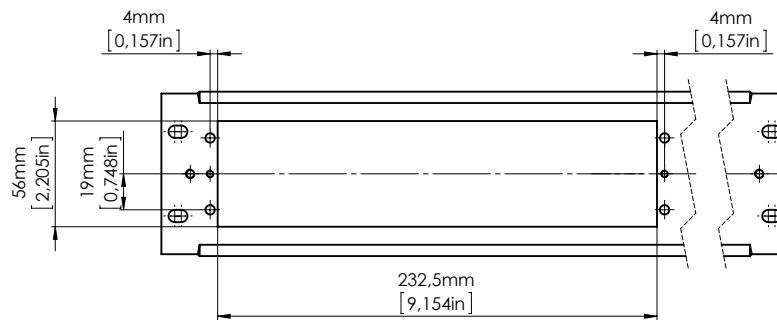

Wiring

Electrical connection terminals are located on the top and bottom of the back side of the ITS Test Block. The connection terminals accept ring cable lugs and spade cable lugs. Use the included special phillips cross recessed pan head screws (UNC thread). The screws are magnetic and can be mounted with power screwdrivers (fastening torque 1.2 Nm).

Do not use metric or other improper screws or warranty will be void.

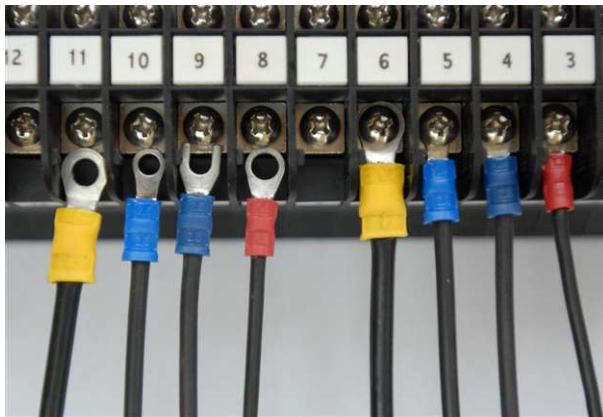

Recommended wire gauge is from 1,5 mm² (AWG 16) to 4 mm² (AWG 12).

CTs should be wired to the terminals provided for this purpose (in 2- or 4-pole combinations) to ensure automatic short circuiting upon insertion of STP Test Plugs or individual test probes into the ITS Test Block. The terminals designated for the connection of the CTs can be typically identified by the

C-	-C
----	----

 or

C-	-C-	-C-	-C
----	-----	-----	----

 labeling¹.

In addition to the two rows of labeling in the front, the ITS Test Block has one row of labels each on the top, back and bottom side (when installed horizontally). All "poles" (or test block modules) are continuously numbered in the same way as it done on the front of the test block (e.g. from 1 through 20 for a 20-pole test block). Pole number 1 (as seen from the front) is also numbered 1 when seen from the back side.

Each "pole" (or test block module) has two connection terminals that receive the same number as the pole itself. One label on each the top side and the bottom side of the test block (when installed horizontally) indicate with the letter "a" or "b" if the terminals on that side are associated with the "A-SIDE" (system side), or "B-SIDE" (device side).

¹custom labeling may show other symbols or use other colors.

3. INSTALLATION



ITS functionality requires that the B-SIDE (device side) of the test block must be connected with the device to be tested (e.g. protective relay), and the A-SIDE (system side) must be connected to the electrical system (e.g. CTs, PTs and breakers).

Following figures represent the top, back and bottom side labeling of a typical ITS Test Block.

7-pole Models

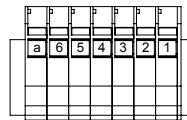
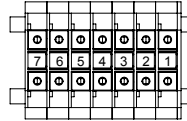
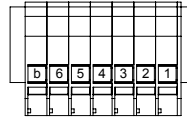

10-pole Models

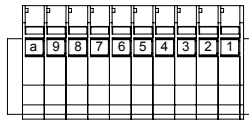
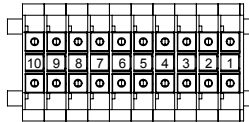
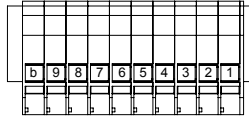

14-pole Models

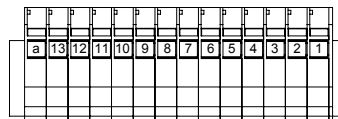
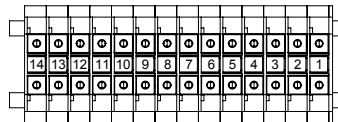
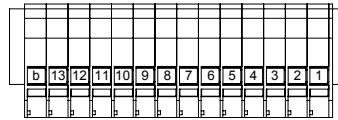

3. INSTALLATION

20-pole Models

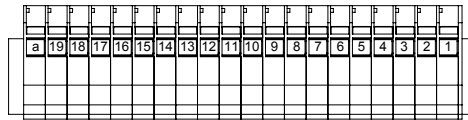
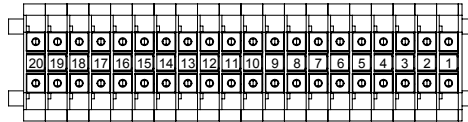
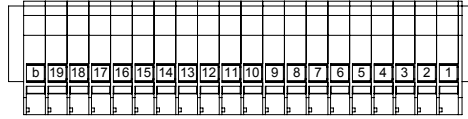

4 Operation

Handling of STP Test Plugs and test probes (smaller plugs for individual circuits) should be done using only the handle and/or insulated plastic parts, since the fingers may be connected to live equipment either via the test block or test equipment.



Store the STP Test Plugs and test probes carefully in order to avoid damage to the metallic test fingers. **SECUCONTROL** recommends using one of the cases listed under “Accessories” on page 19.



1. Remove the ITS dust cover (if one is used, optional accessory) by unscrewing the two knurled screws that hold it, and lifting it up.
2. Carefully align the STP Test Plug or test probe with the corresponding positions on the ITS Test Block.
3. Insert the STP Test Plug or test probe in one smooth and even movement into the ITS Test Block.

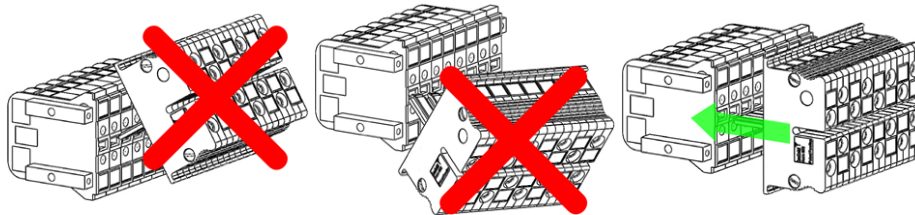

Even insertion means that the test plug should always be positioned in a line parallel to the test block while inserting - not at an angle.

There is no need to externally short-circuit the current transformers, since the STP Test Plugs and test probes have internal shorting bars which will automatically short circuit the corresponding circuits before opening them.

4. Connect cables from the test set with the corresponding STP Test Plug or test probe.

For the purpose of injecting currents and voltages into the connected device (e.g. relay), the test set must be connected to the B-SIDE (device side) of the STP Test Plug or test probe. The connection of the test set to the test plug should be made after the plug has been inserted into the ITS Test Block.



4. OPERATION

5. Once you are ready to resume normal operation, disconnect the cables from the STP Test Plug or test probe.
6. Finally, remove the STP Test Plug or test probe in a single, even and continuous movement.
7. Reattach the dust cover (if one is used).

5 Technical Specifications

Electrical

Current Withstand	30 A continuously 500 A for 1 second
Maximum voltage	600 V
Contact resistance	$\leq 2 \text{ m}\Omega$
Dielectric Withstand	3.0 kV RMS for 1 minute between adjacent contact pairs and between any contact pair and other metal parts 2.0 kV RMS for 1 minute between open contacts when test plug is inserted
Voltage Impulse	3 positive and 3 negative impulses of 5 kV peak, 1.2/50 μs , 0.5 J between adjacent contact pairs and between all contact pairs and other metal parts
UL94 Flammability Class	V-0
Enclosure Protection	IP20 without cover IP50 with optional dust cover attached

ITS / STP has been classified as electromagnetically benign by the Guide for the EMC Directive 2004/108/EC and is, therefore, excluded from the scope of the EMC Directive.

ITS / STP meet or exceed all requirements from ANSI / IEEE C37.90-2005.

5. TECHNICAL SPECIFICATIONS

Mechanical

# of poles		7	10	14	20
ITS Weight	(kg)	0,49	0,67	0,91	1,26
	(lbs)	1,08	1,48	2,01	2,78
STP Weight (without Handle)	(kg)	0,33	0,46	0,65	0,93
	(lbs)	0,73	1,01	1,43	2,05
STP Weight (with Handle)	(kg)	0,54	0,69	0,90	1,21
	(lbs)	1,19	1,52	1,98	2,67
STP Weight (with fitting screws)	(kg)	0,57	0,73	0,94	1,25
	(lbs)	1,26	1,61	2,07	2,76

The above table shows typical standard sizes. Please contact **SECUCONTROL** for additional information regarding other pole lengths.

Dimensional Drawings

7-pole Models



10-pole Models

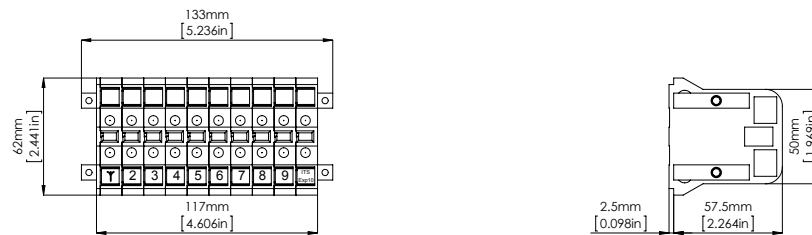

14-pole Models

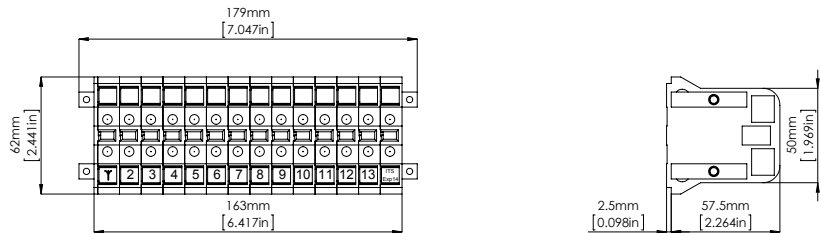

20-pole Models

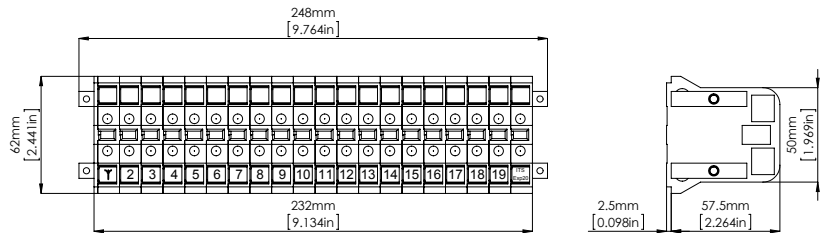

6 Accessories

Cases for STP Test Plugs

Rugged case for STP Test Plugs and test probes.

Description	Order Code
Case for STP Test Plug with handle (HSB)	CSTP1
Case for STP Test Plug without handle and test probes	CSTP2



Individual Test Probes

These test probes will fit all ITS Test Blocks, regardless of configuration. Keying in the probes prevents insertion into wrong circuits (ie, 2-pole current probes can only be inserted into a 2-pole current part of an ITS Test Block).

Current probes include internal shorting bridge.

Description	Order Code
Single pole probe (voltage)	STP-4601PSP01H
Single pole probe (signal)	STP-4601PSP02H
Single pole probe (trip)	STP-4601PSP03H
2-pole probe (single current and return)	STP-4602PSP04H
3-pole probe (three voltages)	STP-4603PSP05H
4-pole probe (four voltages)	STP-4604PSP06H
4-pole probe (three currents, common return)	STP-4604PSP07H
6-pole probe (three currents and return)	STP-4606PSP08H

Universal Test Probes Set

Set of individual test probes in a rugged case. Two configurations are available:

“Small” Set

- 3 × 2-pole current probes (for single currents and return)
- 1 × 4-pole current probes (for three currents and common return)
- 6 × single pole probes (for voltages, trips and signals)

“Large” Set

- 6 × 2-pole current probes (for single currents and return)
- 2 × 4-pole current probes (for three currents and common return)
- 12 × single pole probes (for voltages, trips and signals)

Description	Order Code
Universal Test Probe Set “Small”	USTP1
Universal Test Probe Set “Large”	USTP2

Handles for STP Test Plugs

STP Test Plugs can be built with a handle, which helps with the easy and even insertion into the test block (in particular for test blocks with many poles).

The handle option needs to be specified upon test plug order - please compare the ordering information section of this document.

Three handle options are available:

- STP Test Plug with standard handle
- STP Test Plug with handle, with two fitting screws (M4) to affix the plug to the panel during testing. These fitting screws are compatible with the threaded hole cutouts required for **SECUCONTROL** ITS dust covers
- STP Test Plug with handle, with fitting screws (6-32 UNC) to affix the plug to the panel during testing. Note: the 6-32 thread is NOT compatible with the threaded hole cutouts for standard **SECUCONTROL** dust covers (M4)

Dust Covers for ITS Test Blocks

SECUCONTROL ITS dust covers are attached via two knurled screws (M4). If dust covers will be used, two threaded holes (M4) needs to be cut in the panel at the positions shown on the panel cutout diagram (compare the Installation section of this document).

# of poles	Order Code See-Through Plastic	Order Code Metal, ANSI grey
7	ITSDC07ST	ITSDC07AG
10	ITSDC10ST	ITSDC10AG
14	ITSDC14ST	ITSDC14AG
20	ITSDC20ST	ITSDC20AG

Please contact **SECUCONTROL** for custom products that are not listed above.

7 Spare Parts

Fitting Screws

M4x10 button head screws with hexagon socket (2.5mm) to fix the ITS Test Block in the panel cutout.

Description	Order Code
M4x10 button head screw 10pcs.	SCR401



Connection Screws

8-32 UNC x 3/8" phillips cross recessed pan head screws for connection terminals.

Description	Order Code
8-32 UNC x 3/8" screw 10pcs.	SCR001



8 Ordering Information

Part Numbers for ITS Test Block (4600-Series)

I T S 4 6	<input type="checkbox"/>	<input type="checkbox"/>	B	<input type="checkbox"/>	<input type="checkbox"/>	<input type="checkbox"/>	<input type="checkbox"/>	H
7 pole	0	7						
10 pole	1	0						
14 pole	1	4						
20 pole	2	0						
Standard configurations				S	B			
Ten-pole configurations				T	B			
Additional configurations				A	B			
Configuration Number (1 to 27)						*	*	

Part Numbers for STP Test Plug(4600-Series)

S	T	P	4	6	□	□	□	□	□	□	H
	7 pole	0	7								
	10 pole	1	0								
	14 pole	1	4								
	20 pole	2	0								
	Without handle									P	
	With handle									K	
	With handle and fitting screws 6-32 UNC									H	
	With handle and fitting screws M4									L	
	Standard configurations									S	B
	Ten-pole configurations									T	B
	Additional configurations									A	B
	Configuration Number (1 to 27)									*	*

Configuration Selection Chart



Common standard configurations available from **SECUCONTROL** are listed on the following pages.

Should your application require a configuration that is not listed below, please use our on-line configuration tool at www.secucontrol.com. Alternatively, you may contact **SECUCONTROL** at any of the addresses listed on the rear cover of this manual.

Abbreviation	Description
CS	Current shorting bar is integrated in the probe.
LF	Long finger in the probe, this module opens first.

7-pole Models

Config	Label	Description
SB 01 H		V V V V <u>T T T</u> LF
SB 01 H		

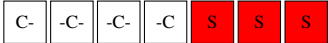
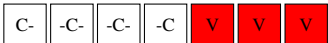
Config	Label	Description
AB 01 H		$\underbrace{T T T T T T T}_{LF}$
AB 01 H		
Config	Label	Description
AB 02 H		V V V V V V V
AB 02 H		
Config	Label	Description
AB 03 H		$\underbrace{C-C-C-C}_{CS} \underbrace{T T T}_{LF}$
AB 03 H		
Config	Label	Description
AB 04 H		$\underbrace{C-C-C-C}_{CS} V V V$
AB 04 H		

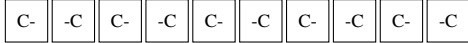

10-pole Models

Config	Label	Description
TB 01 H		V V V V V V V V V
TB 01 H		
Config	Label	Description
TB 02 H		$\underbrace{C-C}_{CS} \underbrace{C-C}_{CS} \underbrace{C-C}_{CS} \underbrace{C-C}_{CS} \underbrace{C-C}_{CS}$
TB 02 H		



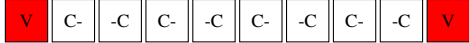

8. ORDERING INFORMATION

Config	Label	Description
TB 03 H		V $\underbrace{C-C}_{CS}$ V $\underbrace{C-C}_{CS}$ V $\underbrace{C-C}_{CS}$ V
TB 03 H		v c- -c v c- -c v c- -c v
Config	Label	Description
TB 04 H		V V V V $\underbrace{C-C}_{CS}$ $\underbrace{C-C}_{CS}$ $\underbrace{C-C}_{CS}$
TB 04 H		v v v v c- -c c- -c c- -c
Config	Label	Description
TB 05 H		V V V $\underbrace{C-C}_{CS}$ $\underbrace{C-C}_{CS}$ $\underbrace{C-C}_{CS}$ V
TB 05 H		v v v c- -c c- -c c- -c v
Config	Label	Description
TB 06 H		V V V $\underbrace{C-C}_{CS}$ V V $\underbrace{C-C}_{CS}$ V
TB 06 H		v v v c- -c v v c- -c v
Config	Label	Description
TB 07 H		V V $\underbrace{C-C-C-C}_{CS}$ $\underbrace{C-C-C-C}_{CS}$
TB 07 H		v v c- -c -c -c c- -c -c -c
Config	Label	Description
TB 08 H		V $\underbrace{C-C-C-C}_{CS}$ V $\underbrace{C-C-C-C}_{CS}$
TB 08 H		v c- -c -c -c v c- -c -c -c

Configuration Selection Chart

Config	Label	Description
TB 09 H		V $\underbrace{C-C}_{CS}$ $\underbrace{C-C}_{CS}$ $\underbrace{C-C}_{CS}$ $\underbrace{C-C}_{CS}$ V
TB 09 H		
Config	Label	Description
TB 10 H		V V V V V V $\underbrace{C-C}_{CS}$ V
TB 10 H		

14-pole Models

Config	Label	Description
SB 02 H		V V V V $\underbrace{T T T T T T T T T T}_{LF}$
SB 02 H		
Config	Label	Description
SB 03 H		$\underbrace{C-C}_{CS}$ $\underbrace{C-C}_{CS}$ $\underbrace{C-C}_{CS}$ $\underbrace{T T T T T T T T T T}_{LF}$
SB 03 H		
Config	Label	Description
SB 04 H		$\underbrace{C-C-C-C}_{CS}$ $\underbrace{T T T T T T T T T T}_{LF}$
SB 04 H		
Config	Label	Description
SB 05 H		$\underbrace{C-C-C-C}_{CS}$ V V V V $\underbrace{T T T T T T T T}_{LF}$
SB 05 H		

8. ORDERING INFORMATION

Config	Label	Description																
SB 06 H		$\underbrace{C-C}_{CS} V V V V V V \underbrace{T T T T T T}_{LF}$																
SB 06 H		<table border="1" style="display: inline-table; border-collapse: collapse;"> <tr> <td style="background-color: #f0f0f0;">C-</td> <td style="background-color: #f0f0f0;">-C</td> <td style="background-color: #ff0000;">V</td> <td style="background-color: #ff0000;">V</td> <td style="background-color: #ff0000;">V</td> <td style="background-color: #ff0000;">V</td> <td style="background-color: #ff0000;">V</td> <td style="background-color: #ff0000;">V</td> <td style="background-color: #ff0000;">V</td> <td style="background-color: #ff0000;">S</td> <td style="background-color: #ff0000;">S</td> <td style="background-color: #ff0000;">S</td> <td style="background-color: #ff0000;">S</td> <td style="background-color: #ff0000;">S</td> <td style="background-color: #ff0000;">S</td> <td style="background-color: #ff0000;">T</td> </tr> </table>	C-	-C	V	V	V	V	V	V	V	S	S	S	S	S	S	T
C-	-C	V	V	V	V	V	V	V	S	S	S	S	S	S	T			
Config	Label	Description																
SB 07 H		$\underbrace{C-C}_{CS} \underbrace{C-C}_{CS} \underbrace{C-C}_{CS} \underbrace{C-C}_{CS} \underbrace{T T T T T T}_{LF}$																
SB 07 H		<table border="1" style="display: inline-table; border-collapse: collapse;"> <tr> <td style="background-color: #f0f0f0;">C-</td> <td style="background-color: #f0f0f0;">-C</td> <td style="background-color: #f0f0f0;">C-</td> <td style="background-color: #f0f0f0;">-C</td> <td style="background-color: #f0f0f0;">C-</td> <td style="background-color: #f0f0f0;">-C</td> <td style="background-color: #f0f0f0;">C-</td> <td style="background-color: #f0f0f0;">-C</td> <td style="background-color: #ff0000;">S</td> <td style="background-color: #ff0000;">S</td> <td style="background-color: #ff0000;">S</td> <td style="background-color: #ff0000;">S</td> <td style="background-color: #ff0000;">S</td> <td style="background-color: #ff0000;">S</td> <td style="background-color: #ff0000;">S</td> <td style="background-color: #ff0000;">T</td> </tr> </table>	C-	-C	C-	-C	C-	-C	C-	-C	S	S	S	S	S	S	S	T
C-	-C	C-	-C	C-	-C	C-	-C	S	S	S	S	S	S	S	T			
Config	Label	Description																
SB 08 H		$\underbrace{C-C-C-C}_{CS} \underbrace{C-C}_{CS} \underbrace{T T T T T T T T}_{LF}$																
SB 08 H		<table border="1" style="display: inline-table; border-collapse: collapse;"> <tr> <td style="background-color: #f0f0f0;">C-</td> <td style="background-color: #f0f0f0;">-C</td> <td style="background-color: #f0f0f0;">-C</td> <td style="background-color: #f0f0f0;">-C</td> <td style="background-color: #f0f0f0;">C-</td> <td style="background-color: #f0f0f0;">-C</td> <td style="background-color: #ff0000;">S</td> <td style="background-color: #ff0000;">S</td> <td style="background-color: #ff0000;">S</td> <td style="background-color: #ff0000;">S</td> <td style="background-color: #ff0000;">S</td> <td style="background-color: #ff0000;">S</td> <td style="background-color: #ff0000;">S</td> <td style="background-color: #ff0000;">S</td> <td style="background-color: #ff0000;">S</td> <td style="background-color: #ff0000;">T</td> </tr> </table>	C-	-C	-C	-C	C-	-C	S	S	S	S	S	S	S	S	S	T
C-	-C	-C	-C	C-	-C	S	S	S	S	S	S	S	S	S	T			
Config	Label	Description																
AB 05 H		$\underbrace{T T T T T T T T T T T T T T T T}_{LF}$																
AB 05 H		<table border="1" style="display: inline-table; border-collapse: collapse;"> <tr> <td style="background-color: #ff0000;">S</td> <td style="background-color: #ff0000;">S</td> <td style="background-color: #ff0000;">S</td> <td style="background-color: #ff0000;">S</td> <td style="background-color: #ff0000;">S</td> <td style="background-color: #ff0000;">S</td> <td style="background-color: #ff0000;">S</td> <td style="background-color: #ff0000;">S</td> <td style="background-color: #ff0000;">S</td> <td style="background-color: #ff0000;">S</td> <td style="background-color: #ff0000;">S</td> <td style="background-color: #ff0000;">S</td> <td style="background-color: #ff0000;">S</td> <td style="background-color: #ff0000;">S</td> <td style="background-color: #ff0000;">S</td> <td style="background-color: #ff0000;">S</td> </tr> </table>	S	S	S	S	S	S	S	S	S	S	S	S	S	S	S	S
S	S	S	S	S	S	S	S	S	S	S	S	S	S	S	S			
Config	Label	Description																
AB 06 H		V V V V V V V V V V V V V V V V																
AB 06 H		<table border="1" style="display: inline-table; border-collapse: collapse;"> <tr> <td style="background-color: #ff0000;">V</td> <td style="background-color: #ff0000;">V</td> <td style="background-color: #ff0000;">V</td> <td style="background-color: #ff0000;">V</td> <td style="background-color: #ff0000;">V</td> <td style="background-color: #ff0000;">V</td> <td style="background-color: #ff0000;">V</td> <td style="background-color: #ff0000;">V</td> <td style="background-color: #ff0000;">V</td> <td style="background-color: #ff0000;">V</td> <td style="background-color: #ff0000;">V</td> <td style="background-color: #ff0000;">V</td> <td style="background-color: #ff0000;">V</td> <td style="background-color: #ff0000;">V</td> <td style="background-color: #ff0000;">V</td> <td style="background-color: #ff0000;">V</td> </tr> </table>	V	V	V	V	V	V	V	V	V	V	V	V	V	V	V	V
V	V	V	V	V	V	V	V	V	V	V	V	V	V	V	V			
Config	Label	Description																
AB 07 H		$\underbrace{C-C-C-C}_{CS} \underbrace{C-C-C-C}_{CS} \underbrace{C-C-C-C}_{CS} \underbrace{T T}_{LF}$																
AB 07 H		<table border="1" style="display: inline-table; border-collapse: collapse;"> <tr> <td style="background-color: #f0f0f0;">C-</td> <td style="background-color: #f0f0f0;">-C</td> <td style="background-color: #f0f0f0;">-C</td> <td style="background-color: #f0f0f0;">-C</td> <td style="background-color: #f0f0f0;">C-</td> <td style="background-color: #f0f0f0;">-C</td> <td style="background-color: #f0f0f0;">-C</td> <td style="background-color: #f0f0f0;">-C</td> <td style="background-color: #f0f0f0;">C-</td> <td style="background-color: #f0f0f0;">-C</td> <td style="background-color: #f0f0f0;">-C</td> <td style="background-color: #f0f0f0;">-C</td> <td style="background-color: #ff0000;">S</td> <td style="background-color: #ff0000;">S</td> </tr> </table>	C-	-C	-C	-C	C-	-C	-C	-C	C-	-C	-C	-C	S	S		
C-	-C	-C	-C	C-	-C	-C	-C	C-	-C	-C	-C	S	S					

20-pole Models

Config	Label	Description
SB 09 H		$\underbrace{C-C}_{CS} \underbrace{C-C}_{CS} \underbrace{C-C}_{CS} \underbrace{C-C}_{CS} V V V V V V V V \underbrace{T T T T}_{LF}$
SB 09 H		<div style="display: flex; justify-content: space-between; border: 1px solid black; padding: 2px;"> C- -C C- -C C- -C C- -C V V V V V V V V S S S S T </div>
Config	Label	Description
SB 10 H		$\underbrace{C-C-C-C}_{CS} \underbrace{C-C}_{CS} V V V V V V V V \underbrace{T T T T T T}_{LF}$
SB 10 H		<div style="display: flex; justify-content: space-between; border: 1px solid black; padding: 2px;"> C- -C -C -C C- -C V V V V V V V V V S S S S S S T </div>
Config	Label	Description
SB 11 H		$\underbrace{C-C}_{CS} \underbrace{C-C}_{CS} \underbrace{C-C}_{CS} \underbrace{C-C}_{CS} \underbrace{C-C}_{CS} \underbrace{C-C}_{CS} \underbrace{C-C}_{CS} \underbrace{C-C}_{CS} V V V V \underbrace{T T}_{LF}$
SB 11 H		<div style="display: flex; justify-content: space-between; border: 1px solid black; padding: 2px;"> C- -C C- -C C- -C C- -C C- -C C- -C C- -C V V V V S T </div>
Config	Label	Description
SB 12 H		$\underbrace{C-C-C-C}_{CS} \underbrace{C-C-C-C}_{CS} \underbrace{C-C}_{CS} V V V V \underbrace{T T T T T T}_{LF}$
SB 12 H		<div style="display: flex; justify-content: space-between; border: 1px solid black; padding: 2px;"> C- -C -C -C C- -C -C -C C- -C V V V V S S S S S S T </div>
Config	Label	Description
SB 13 H		$\underbrace{C-C}_{CS} \underbrace{C-C}_{CS} \underbrace{C-C}_{CS} \underbrace{C-C}_{CS} V V V V V V \underbrace{T T T T T T}_{LF}$
SB 13 H		<div style="display: flex; justify-content: space-between; border: 1px solid black; padding: 2px;"> C- -C C- -C C- -C C- -C V V V V V V S S S S S S T </div>
Config	Label	Description
SB 14 H		$\underbrace{C-C-C-C}_{CS} \underbrace{C-C}_{CS} V V V V V V \underbrace{T T T T T T T T}_{LF}$
SB 14 H		<div style="display: flex; justify-content: space-between; border: 1px solid black; padding: 2px;"> C- -C -C -C C- -C V V V V V V S S S S S S S S T </div>

Configuration Selection Chart

Config	Label	Description
SB 21 H		$\underbrace{C-C}_{CS} \underbrace{C-C}_{CS} \underbrace{C-C}_{CS} \underbrace{C-C}_{CS} \underbrace{C-C}_{CS} \underbrace{C-C}_{CS} V V V V \underbrace{T T T T}_{LF}$
SB 21 H		<div style="display: flex; justify-content: space-between; align-items: center;"> <div style="display: flex; gap: 5px;"> <div style="border: 1px solid black; padding: 2px 5px;">C-</div> <div style="border: 1px solid black; padding: 2px 5px;">-C</div> <div style="border: 1px solid black; padding: 2px 5px;">C-</div> <div style="border: 1px solid black; padding: 2px 5px;">-C</div> <div style="border: 1px solid black; padding: 2px 5px;">C-</div> <div style="border: 1px solid black; padding: 2px 5px;">-C</div> <div style="border: 1px solid black; padding: 2px 5px;">C-</div> <div style="border: 1px solid black; padding: 2px 5px;">-C</div> <div style="border: 1px solid black; padding: 2px 5px;">C-</div> <div style="border: 1px solid black; padding: 2px 5px;">-C</div> <div style="border: 1px solid black; padding: 2px 5px;">C-</div> <div style="border: 1px solid black; padding: 2px 5px;">-C</div> </div> <div style="display: flex; gap: 5px;"> <div style="background-color: red; color: white; padding: 2px 5px;">V</div> <div style="background-color: red; color: white; padding: 2px 5px;">V</div> <div style="background-color: red; color: white; padding: 2px 5px;">V</div> <div style="background-color: red; color: white; padding: 2px 5px;">V</div> <div style="background-color: red; color: white; padding: 2px 5px;">S</div> <div style="background-color: red; color: white; padding: 2px 5px;">S</div> <div style="background-color: red; color: white; padding: 2px 5px;">S</div> <div style="background-color: red; color: white; padding: 2px 5px;">S</div> <div style="background-color: red; color: white; padding: 2px 5px;">T</div> </div> </div>
SB 22 H		$\underbrace{C-C-C-C}_{CS} \underbrace{C-C-C-C}_{CS} V V V V \underbrace{T T T T T T T T}_{LF}$
SB 22 H		<div style="display: flex; justify-content: space-between; align-items: center;"> <div style="display: flex; gap: 5px;"> <div style="border: 1px solid black; padding: 2px 5px;">C-</div> <div style="border: 1px solid black; padding: 2px 5px;">-C</div> <div style="border: 1px solid black; padding: 2px 5px;">-C</div> <div style="border: 1px solid black; padding: 2px 5px;">-C</div> <div style="border: 1px solid black; padding: 2px 5px;">C-</div> <div style="border: 1px solid black; padding: 2px 5px;">-C</div> <div style="border: 1px solid black; padding: 2px 5px;">-C</div> <div style="border: 1px solid black; padding: 2px 5px;">-C</div> </div> <div style="display: flex; gap: 5px;"> <div style="background-color: red; color: white; padding: 2px 5px;">V</div> <div style="background-color: red; color: white; padding: 2px 5px;">V</div> <div style="background-color: red; color: white; padding: 2px 5px;">V</div> <div style="background-color: red; color: white; padding: 2px 5px;">V</div> <div style="background-color: red; color: white; padding: 2px 5px;">S</div> <div style="background-color: red; color: white; padding: 2px 5px;">S</div> <div style="background-color: red; color: white; padding: 2px 5px;">S</div> <div style="background-color: red; color: white; padding: 2px 5px;">S</div> <div style="background-color: red; color: white; padding: 2px 5px;">S</div> <div style="background-color: red; color: white; padding: 2px 5px;">S</div> <div style="background-color: red; color: white; padding: 2px 5px;">S</div> <div style="background-color: red; color: white; padding: 2px 5px;">S</div> <div style="background-color: red; color: white; padding: 2px 5px;">T</div> </div> </div>
SB 23 H		$\underbrace{C-C}_{CS} \underbrace{C-C}_{CS} \underbrace{C-C}_{CS} \underbrace{C-C}_{CS} \underbrace{C-C}_{CS} \underbrace{C-C}_{CS} \underbrace{C-C}_{CS} \underbrace{C-C}_{CS} \underbrace{C-C}_{CS} \underbrace{T T}_{LF}$
SB 23 H		<div style="display: flex; justify-content: space-between; align-items: center;"> <div style="display: flex; gap: 5px;"> <div style="border: 1px solid black; padding: 2px 5px;">C-</div> <div style="border: 1px solid black; padding: 2px 5px;">-C</div> <div style="border: 1px solid black; padding: 2px 5px;">C-</div> <div style="border: 1px solid black; padding: 2px 5px;">-C</div> <div style="border: 1px solid black; padding: 2px 5px;">C-</div> <div style="border: 1px solid black; padding: 2px 5px;">-C</div> <div style="border: 1px solid black; padding: 2px 5px;">C-</div> <div style="border: 1px solid black; padding: 2px 5px;">-C</div> <div style="border: 1px solid black; padding: 2px 5px;">C-</div> <div style="border: 1px solid black; padding: 2px 5px;">-C</div> <div style="border: 1px solid black; padding: 2px 5px;">C-</div> <div style="border: 1px solid black; padding: 2px 5px;">-C</div> <div style="border: 1px solid black; padding: 2px 5px;">C-</div> <div style="border: 1px solid black; padding: 2px 5px;">-C</div> <div style="border: 1px solid black; padding: 2px 5px;">C-</div> <div style="border: 1px solid black; padding: 2px 5px;">-C</div> <div style="border: 1px solid black; padding: 2px 5px;">C-</div> <div style="border: 1px solid black; padding: 2px 5px;">-C</div> </div> <div style="display: flex; gap: 5px;"> <div style="background-color: red; color: white; padding: 2px 5px;">S</div> <div style="background-color: red; color: white; padding: 2px 5px;">T</div> </div> </div>
SB 24 H		$\underbrace{C-C-C-C}_{CS} \underbrace{C-C-C-C}_{CS} \underbrace{C-C-C-C}_{CS} \underbrace{T T T T T T T T}_{LF}$
SB 24 H		<div style="display: flex; justify-content: space-between; align-items: center;"> <div style="display: flex; gap: 5px;"> <div style="border: 1px solid black; padding: 2px 5px;">C-</div> <div style="border: 1px solid black; padding: 2px 5px;">-C</div> <div style="border: 1px solid black; padding: 2px 5px;">-C</div> <div style="border: 1px solid black; padding: 2px 5px;">-C</div> <div style="border: 1px solid black; padding: 2px 5px;">C-</div> <div style="border: 1px solid black; padding: 2px 5px;">-C</div> <div style="border: 1px solid black; padding: 2px 5px;">-C</div> <div style="border: 1px solid black; padding: 2px 5px;">-C</div> <div style="border: 1px solid black; padding: 2px 5px;">C-</div> <div style="border: 1px solid black; padding: 2px 5px;">-C</div> <div style="border: 1px solid black; padding: 2px 5px;">-C</div> <div style="border: 1px solid black; padding: 2px 5px;">-C</div> </div> <div style="display: flex; gap: 5px;"> <div style="background-color: red; color: white; padding: 2px 5px;">S</div> <div style="background-color: red; color: white; padding: 2px 5px;">S</div> <div style="background-color: red; color: white; padding: 2px 5px;">S</div> <div style="background-color: red; color: white; padding: 2px 5px;">S</div> <div style="background-color: red; color: white; padding: 2px 5px;">S</div> <div style="background-color: red; color: white; padding: 2px 5px;">S</div> <div style="background-color: red; color: white; padding: 2px 5px;">S</div> <div style="background-color: red; color: white; padding: 2px 5px;">S</div> <div style="background-color: red; color: white; padding: 2px 5px;">T</div> </div> </div>
SB 25 H		$\underbrace{C-C-C-C}_{CS} \underbrace{C-C-C-C}_{CS} \underbrace{C-C-C-C}_{CS} \underbrace{C-C-C-C}_{CS} \underbrace{T T T T}_{LF}$
SB 25 H		<div style="display: flex; justify-content: space-between; align-items: center;"> <div style="display: flex; gap: 5px;"> <div style="border: 1px solid black; padding: 2px 5px;">C-</div> <div style="border: 1px solid black; padding: 2px 5px;">-C</div> <div style="border: 1px solid black; padding: 2px 5px;">-C</div> <div style="border: 1px solid black; padding: 2px 5px;">-C</div> <div style="border: 1px solid black; padding: 2px 5px;">C-</div> <div style="border: 1px solid black; padding: 2px 5px;">-C</div> <div style="border: 1px solid black; padding: 2px 5px;">-C</div> <div style="border: 1px solid black; padding: 2px 5px;">-C</div> <div style="border: 1px solid black; padding: 2px 5px;">C-</div> <div style="border: 1px solid black; padding: 2px 5px;">-C</div> <div style="border: 1px solid black; padding: 2px 5px;">-C</div> <div style="border: 1px solid black; padding: 2px 5px;">-C</div> <div style="border: 1px solid black; padding: 2px 5px;">C-</div> <div style="border: 1px solid black; padding: 2px 5px;">-C</div> <div style="border: 1px solid black; padding: 2px 5px;">-C</div> <div style="border: 1px solid black; padding: 2px 5px;">-C</div> </div> <div style="display: flex; gap: 5px;"> <div style="background-color: red; color: white; padding: 2px 5px;">S</div> <div style="background-color: red; color: white; padding: 2px 5px;">S</div> <div style="background-color: red; color: white; padding: 2px 5px;">S</div> <div style="background-color: red; color: white; padding: 2px 5px;">T</div> </div> </div>
SB 26 H		$\underbrace{C-C}_{CS} \underbrace{C-C}_{CS} \underbrace{C-C}_{CS} \underbrace{C-C}_{CS} V V V V \underbrace{T T T T T T T T}_{LF}$
SB 26 H		<div style="display: flex; justify-content: space-between; align-items: center;"> <div style="display: flex; gap: 5px;"> <div style="border: 1px solid black; padding: 2px 5px;">C-</div> <div style="border: 1px solid black; padding: 2px 5px;">-C</div> <div style="border: 1px solid black; padding: 2px 5px;">C-</div> <div style="border: 1px solid black; padding: 2px 5px;">-C</div> <div style="border: 1px solid black; padding: 2px 5px;">C-</div> <div style="border: 1px solid black; padding: 2px 5px;">-C</div> <div style="border: 1px solid black; padding: 2px 5px;">C-</div> <div style="border: 1px solid black; padding: 2px 5px;">-C</div> </div> <div style="display: flex; gap: 5px;"> <div style="background-color: red; color: white; padding: 2px 5px;">V</div> <div style="background-color: red; color: white; padding: 2px 5px;">V</div> <div style="background-color: red; color: white; padding: 2px 5px;">V</div> <div style="background-color: red; color: white; padding: 2px 5px;">V</div> <div style="background-color: red; color: white; padding: 2px 5px;">S</div> <div style="background-color: red; color: white; padding: 2px 5px;">S</div> <div style="background-color: red; color: white; padding: 2px 5px;">S</div> <div style="background-color: red; color: white; padding: 2px 5px;">S</div> <div style="background-color: red; color: white; padding: 2px 5px;">S</div> <div style="background-color: red; color: white; padding: 2px 5px;">S</div> <div style="background-color: red; color: white; padding: 2px 5px;">S</div> <div style="background-color: red; color: white; padding: 2px 5px;">S</div> <div style="background-color: red; color: white; padding: 2px 5px;">T</div> </div> </div>

North America

SecuControl Inc.
2873 Duke Street
Alexandria, VA 22314
USA
Tel +1 703 838 7677
mail@secucontrol.com
www.secucontrol.com

Europe

SecuControl GmbH
Ascherslebener Str. 3
D-06333 Hettstedt
Germany
Tel +49 3476 550 022
info@secucontrol.com
www.secucontrol.com

South America

SecuBrasil Ltda
Rod José Carlos Daux, 8600
88050-001 Florianópolis SC
Brazil
Tel +55 (48) 3371 1670
comercial@secubrasil.com
www.secubrasil.com