

LTB / LTP Test Blocks & Plugs

Reference Handbook

LTB-LTP-reference-en v.147

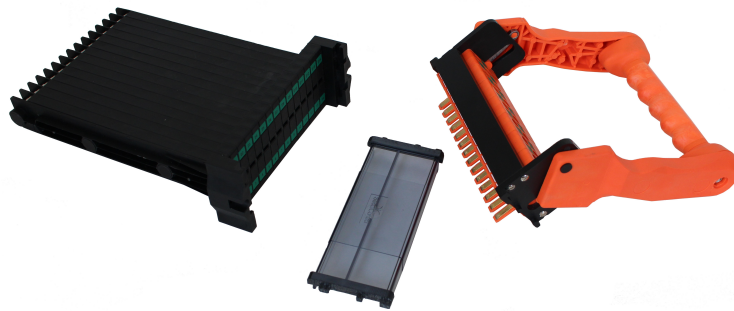

Copyright Notice

All information provided in this document is the property of **SECUCONTROL** .

SECUCONTROL grants its customers or potential customers the right to download, copy, store and print this document for the sole purpose of assisting them in the correct application of the products mentioned in this document.

All other uses of this document are expressly prohibited.

Intellectual Property Notice

This publication contains proprietary information under protection of the following (among others) patents: DE 10 2005 025 108, DE 10 2008 016 388, US 7,271,357 and US 7,884,597.

Contents Disclaimer

Although the information and recommendations in this document are presented in good faith and believed to be correct as of publication date, **SECUCONTROL** makes no representations as to the completeness or accuracy thereof. In no event shall **SECUCONTROL** be responsible for damages of any nature resulting from the use of or reliance upon the contents of this document.

Continuous Improvements

Products developed by **SECUCONTROL** are continuously improved. The information in this document may, therefore, be out of date.

Please make sure you have the latest release of this document before proceeding by checking its name and revision code. This information is printed on the front cover of this document, underneath the title. The latest release of this document can be downloaded from www.secucontrol.com/downloads. Alternatively, you may contact **SECUCONTROL** at any of the addresses provided on the rear cover of this document.

Contents

1	Introduction	1
	The LTB / LTP Test Block & Plug	1
	Key Features	1
	Applicable Models	1
	Unpacking	1
	Part Number and Manufacturing Date Location	2
	Safety Symbols	2
	General Safety Instructions	2
2	Principle of Operation	3
	Closed Circuit	3
	Open Circuit, Signal Injection	3
	Current Transformers	3
3	Application	5
	Schematic Symbols	5
	Typical Connection Schematic	6
4	Installation	7
	Panel Cutouts, Drilling Plans and Mounting	7
	Wiring	8
5	Operation	9
6	Technical Specifications	11
	Electrical	11
	Mechanical	12
	LTB Dimensional Drawings	12
	LTP Dimensional Drawings	13
7	Accessories	15
	Cases for LTP Test Plugs	15
	Individual Test Probes	15
	Universal Test Probes Set	15
	Current Measurement Probe	16
	LTB 19" Rack Plates	16
8	Spare Parts	19
	Dust Covers	19

Fitting Set	19
9 Ordering Information	21
Part Numbers for LTB Test Block	21
Part Numbers for LTP Test Plug	21
Available Configurations	21

1 Introduction

The LTB / LTP Test Block & Plug

The LTB is a test block for interfacing substation devices (protection relays, fault recorders, revenue meters, ...) to the voltage and current transformers and to other equipment on the system side of a power grid.

The LTP is a test plug keyed to a particular configuration of LTB Test Blocks. Once inserted into the corresponding Test Block, the LTP Plug isolates the substation devices from the system side equipment while at the same time allowing connection of test equipment for secondary injection tests.

Key Features

- Finger-safe Test Block and Test Plug increase safety during testing.
- Test Plugs are keyed to the corresponding Test Blocks and help eliminate of the most common human errors during testing.
- Test Plug locks into Test Block for a secure fit without any canting.
- Leverage mechanism supports smooth and effortless insertion of Test Plug.
- Long back end of Test Block typically is flush with adjacent devices and facilitates an effortless cabling.
- Extremely low internal resistance ($< 6 \text{ m}\Omega$) helps reduce heat inside cabinets and panels.
- Available in 7 and 14 pole configurations.

Applicable Models

Information in this document applies to all LTB Test Blocks and LTP Test Plugs manufactured since January 2015.

Unpacking

Unpack the product carefully and make sure that all pertinent parts like dust covers and screws are put aside so they will not be lost.

1. INTRODUCTION

Check the contents against the packing list. If any of the contents listed are missing, please contact **SECUCONTROL** immediately (see contact information at the rear cover of this manual).

Examine the product for any shipping damage. If the product is damaged, notify the shipping company without delay. Only the consignee (the person or company receiving the unit) can file a claim against the carrier for shipping damage.

Part Number and Manufacturing Date Location

Part number and manufacturing date are stated on a label on the right side of the Test Block or Test Plug.

Safety Symbols

The following symbols are located on different parts of the equipment and in this manual:



Paragraphs marked with this symbol contain information which, if not properly followed, may cause damage to the equipment and/or installation.



Paragraphs marked with this symbol contain information which, if not properly followed, may cause personal injury or even death.

General Safety Instructions

Installation and operation of the products described in this manual is only to be performed by personnel that has been trained or is knowledgeable in substation protection, automation and control.

This instruction manual is an integral part of the scope of delivery and provides basic instructions for installation and operation of the equipment here described. Shall additional information be needed, please contact **SECUCONTROL** at any of the addresses provided on the rear cover of this document.



Neither disassemble the Test Block nor the Test Plug. Correct alignment of internal parts is critical in order to provide insulation and arch-avoidance.



The warranty will be void if the Test Block is disassembled (or otherwise handled inappropriately). SecuControl does not assume responsibility for any damages arising out of mishandling of our products, including test blocks that have been disassembled by parties other than SecuControl.

2 Principle of Operation

Closed Circuit



In the resting state the LTB test block's contacts are closed, signals from the system side (side A) are connected by flat springs to the panel devices (side B).

Open Circuit, Signal Injection

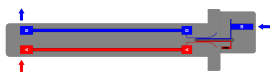

To open the test block's contacts, the LTP Test Plug is inserted into the LTB Test Block. In this situation, the devices in the panel (side B) are isolated from the system side (side A). Signals can be injected using the banana jacks on the front side of the LTP Test Plug.

Current Transformers



The LTP Test Plugs automatically short-circuits the secondaries of current transformers (which are connected to the B side of the block). The short-circuiting happens before the contacts are open ("make-before-break").

3 Application

Schematic Symbols

Following symbols are suggested in order to represent the LTB Test Block in schematic diagrams.

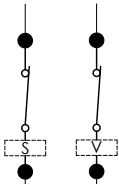
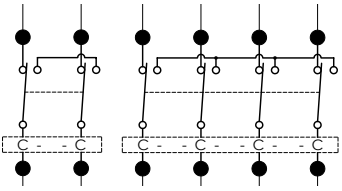
Symbol	Description
	Signal, Voltage (single pole)
	Current (2-pole, 4-pole)

3. APPLICATION

Typical Connection Schematic

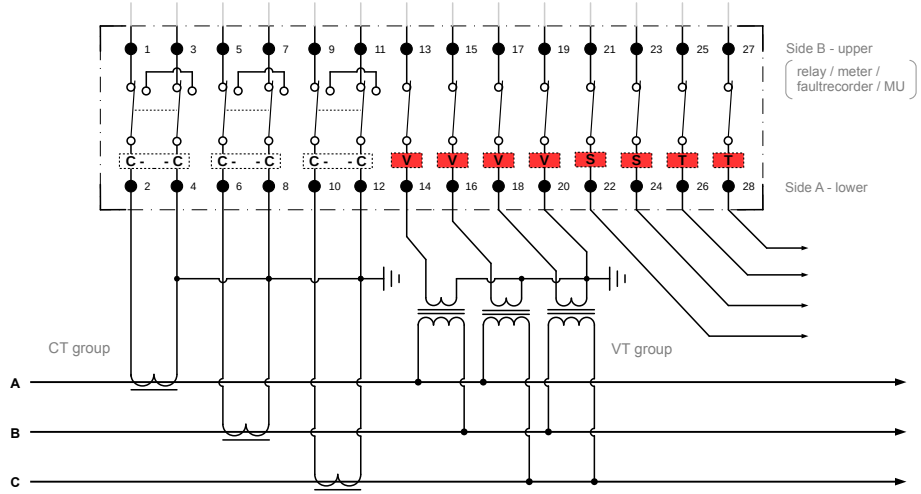

4 Installation

Panel Cutouts, Drilling Plans and Mounting

Use the provided M5x30 screws to fix the LTB Test Block onto the panel. The screws should be tightened using a 4 mm hex drive.

7-pole Models

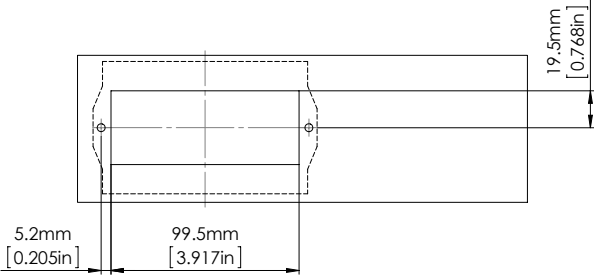

14-pole Models

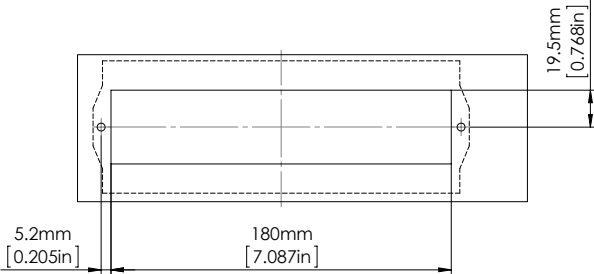

Wiring

Electrical connector sockets are located on the rear of the LTB Test Block. Each of the connector sockets receives a screw in the back and accepts ring or yoke cable lugs, stripped wire or other crimp connectors.

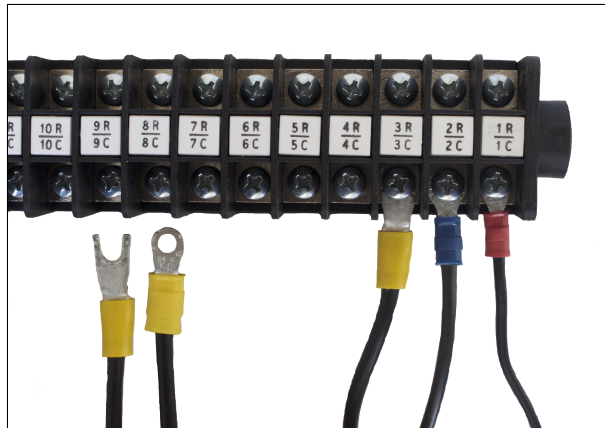

Recommended wire gauge is from 1.5 mm² (AWG 16) to 4 mm² (AWG 12).

CTs should be wired to the terminals provided for this purpose (in 2- or 4-pole combinations) to ensure automatic short circuiting upon insertion of LTP test plugs or individual test probes into the LTB Test Block. The terminals designated for the connection of the CTs can be typically identified by the

C-	-C
----	----

 or

C-	-C-	-C-	-C
----	-----	-----	----

 labeling¹.



The panel equipments (protection relays, meters, fault recorders, etc) should be connected to the device side terminals indicated by the odd-numbers (1, 3, 5, 7, ...), or by the “b” suffix (1b, 2b, 3b, ...), depending on model.



The protection equipments (current and voltage transformers, breaker, etc) should be connected to the system side terminals indicated by the even-numbers (2, 4, 6, 8, ...), or by the “a” suffix (1a, 2a, 3a, ...), depending on model.

¹Custom labeling may show other symbols or use other colors.

5 Operation

Handling of the LTP Test Plugs or Test Probes should be done using only the handle and/or insulated plastic parts, since the fingers may be connected to live equipment either via the test block or test equipment.

Store the LTP Test Plugs and Test Probes carefully in order to avoid damage to the metallic test fingers. **SECUCONTROL** recommends using one of the cases listed under “Accessories” on page 15.



1. Remove the dust cover by sliding the cover up and then out.
2. Connect cables from the test set onto the corresponding LTP Test Plug or Test Probe.

There is no need to externally short-circuit the current transformers, since the LTP Test Plugs and Test Probes have internal shorting bars which will automatically short circuit the corresponding circuits before opening them.

3. The plug-in process to insert the Test Plug into the Test Block consists of the following steps:

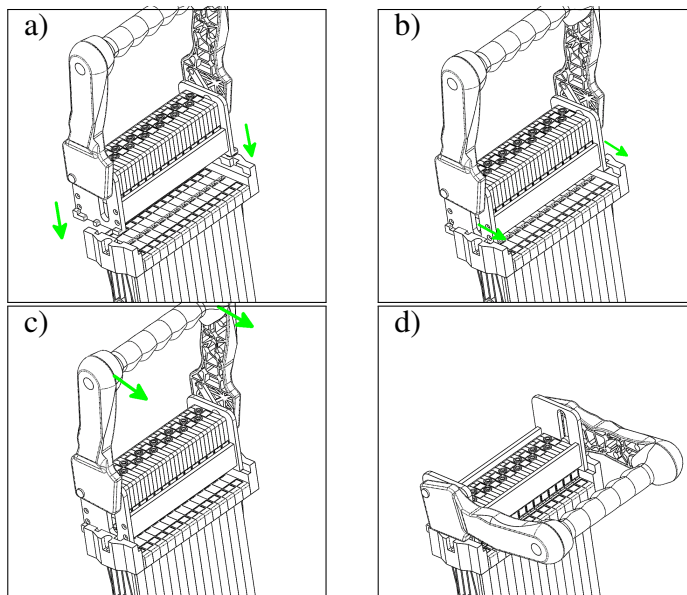

5. OPERATION

- (a) Hook the protruding dents of the LTP Test Plug into the guiding rails of the LTB Test Block.
 - (b) Let the dents slide down in the guiding rails, as far as they go.
 - (c) Push down the handle, as far as it goes.
 - (d) Connect the test set via the banana jacks and start testing.
4. The Test Probes need to be aligned with the corresponding openings of the Test Block and then be inserted in a single continuous movement.
5. Once you are ready to resume normal operation, remove the LTP Test Plug or Test Probe by undoing the steps described in [3](#) and [4](#).
6. Reattach the dust cover.

6 Technical Specifications

Electrical

Current Withstand	25 A continuously 500 A for 1 second
Maximum voltage	600 V
Contact resistance	$\leq 6 \text{ m}\Omega$
Dielectric Withstand	3.0 kV RMS for 1 minute between adjacent contact pairs and between any contact pair and other metal parts 2.0 kV RMS for 1 minute between open contacts when test plug is inserted
Voltage Impulse	3 positive and 3 negative impulses of 5 kV peak, 1.2/50 μs , 0.5 J between adjacent contact pairs and between all contact pairs and other metal parts
Temperature Range	-25 to +70 °C (-13 to +158 °F), storage -25 to +55 °C (-13 to +131 °F), operation
UL94 Flammability Class	V-0
Enclosure Protection	IP20 without cover IP50 with dust cover attached

The LTB / LTP Test Blocks & Test Plugs are classified as electromagnetically benign and are therefore excluded from the scope of the European Community EMC Directive 2004/108/EC.

The LTB / LTP Test Blocks & Test Plugs meet or exceed all requirements from ANSI / IEEE C37.90-2005.

6. TECHNICAL SPECIFICATIONS

Mechanical

	# of poles	7	14
LTB Weight (kg)		0.72	1.27
(lbs)		1.59	2.81
LTP Weight (kg)		0.00	0.00
(lbs)		0.00	0.00

LTB Dimensional Drawings

7-pole Models

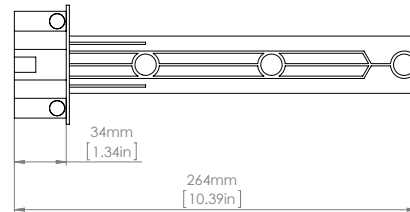
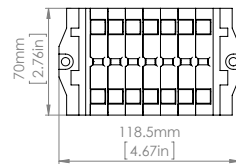

14-pole Models

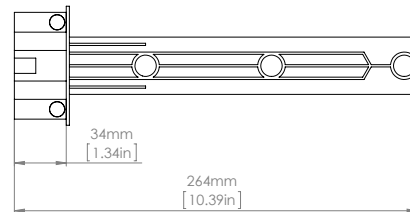
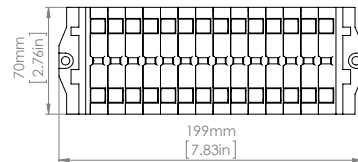

LTP Dimensional Drawings

7-pole Models

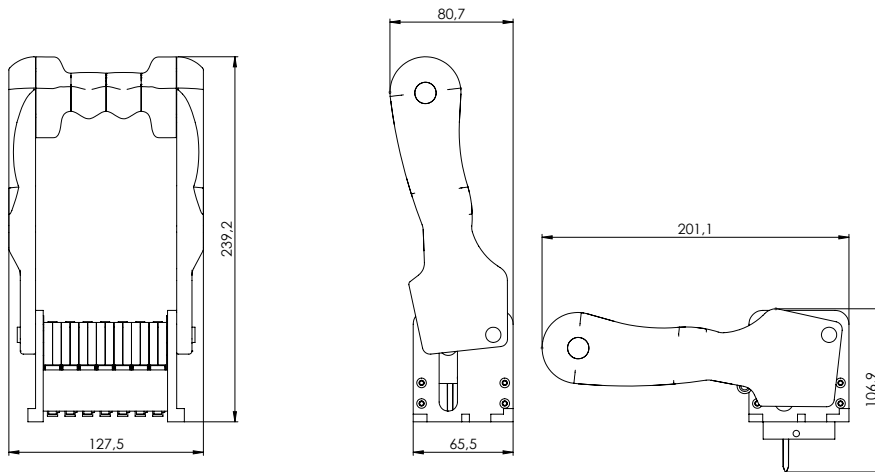

6. TECHNICAL SPECIFICATIONS

14-pole Models

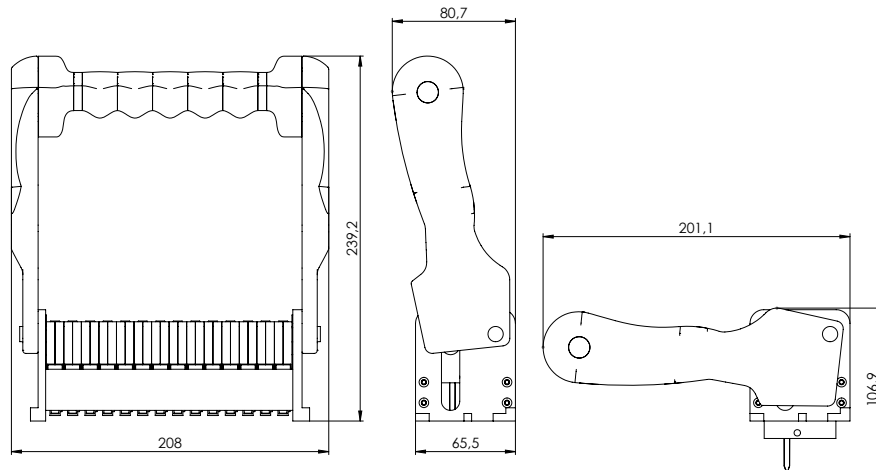

7 Accessories

Cases for LTP Test Plugs

Rugged case for LTP Test Plugs with handle or Test Probes.

Description	Order Code
Case for LTP Test Plug	CLTP1
Case for LTP Test Probes	CLTP2



Individual Test Probes

These probes will fit all LTB Test Blocks, regardless of configuration. Keying in the probes prevents insertion into wrong circuits (i.e., 2-pole current probes can only be inserted into a 2-pole current part of an LTB block).

Current probes include internal shorting bridge.

Description	Order Code
Single pole probe (voltages, signals and trips)	LTPTPGA00AA
2-pole probe (single current and return)	LTPTPGB00AA
4-pole (four voltages)	LTPTPGA40AA
4-pole probe (three currents, common return)	LTPTPGM00AA
6-pole probe (three currents and return)	LTPTPGD00AA

Universal Test Probes Set

Set of individual test probes in a rugged case. Two configurations are available:

“Small” Set

- 3 × 2-pole current probes (for single currents and return)
- 1 × 4-pole current probes (for three currents and common return)

7. ACCESSORIES

- 6 × single pole probes (for voltages, trips and signals)

“Large” Set

- 6 × 2-pole current probes (for single currents and return)
- 2 × 4-pole current probes (for three currents and common return)
- 12 × single pole probes (for voltages, trips and signals)

Description	Order Code
Universal Test Probe Set “Small”	ULTP1AA
Universal Test Probe Set “Large”	ULTP2AA



Current Measurement Probe

This special test probe allows for the connection of a current measurement device or a shunt. The AWG 13 (2.5 mm²) connection cable has a length of 118 inches (3 meters). The test probe is available with c-hook terminals or banana plugs.

The current measurement probe is a special tool that is built for current measurement purposes. It does NOT automatically short-circuit current transformer circuits upon insertion into the LTB test block. Instead, current circuits are opened and redirected via the attached wires once the probe is entered into the test block. The probe must always be correctly connected to a measurement instrument or a shunt before insertion into the LTB test block, to prevent the creation of an open current transformer circuit. The current measurement probe should be used by properly trained personnel only.



Description	Order Code
C-hook connection	UTPC1
Banana plug connection	UTPC2



LTB 19” Rack Plates

SECUCONTROL offers metal plates for installation of LTB test blocks in 19” racks that come painted in various colors and with various cutouts for LTB test blocks, in standard heights of 2U or 3U. Please contact **SECUCONTROL** if you require drawings or special customizations.

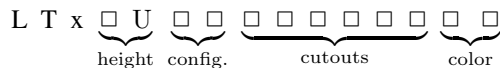

- height** Rack plates are available in 2U and 3U
- config.** A: standard 19" rack plates, 2mm thick with standard cutouts
B-Z: reserved for special configurations
- cutout** e.g. 14xx14 ζ cutout for one 14-pole (left) and one 14-pole (right) LTB test block
e.g. 14xxxx ζ cutout for one 14-pole (left) LTB test block
e.g. xxx14 ζ cutout for one 14-pole (right) LTB test block
e.g. 070707 ζ cutout for one 7-pole (left), one 7-pole (middle) and one 7-pole (right) LTB test blocks
e.g. 070714 ζ cutout for one 7-pole (left), one 7-pole (middle) and one 14-pole (right) LTB test blocks
max. amount of poles per rack plate = 28
- color** These two digits define rack plate colors. Available options can be found in the table below:

Color	Description
AG	ANSI-grey #61
PG	pebble grey RAL 7032
LG	light grey RAL 7035
WG	white gray RAL 9002
BK	black

For all configurations with 2 cutouts and 29 modules (e.g. 2 x 14-pole cutouts), **SECUCONTROL** recommends special LTB fitting screws (M5x22). These screws should be mounted on the far left and the far right side of the rack plate, to prevent the tip of the screws from touching the mounting frame. Two special screws are included with every LTB rack plate with 3 cutouts\29 modules. Please use the order codes below for reordering.



8 Spare Parts

Dust Covers

# of poles	Order Code
7	LTDC07
14	LTDC14

Fitting Set

Fitting set to fix the LTB Test Block in the panel cutout. The screw set contains two M5x30 hexagon socket head cap screws (4 mm) and two M5 nuts.

Description	Order Code
Fitting set M5	SCSFT



9 Ordering Information

Part Numbers for LTB Test Block

L T B A
 poles config labeling

Part Numbers for LTP Test Plug

L T P
 type poles config labeling

where the type is either of the following:

- A ... black color
- B ... partly orange color (otherwise black)

Available Configurations

A list of available Configurations can be found in the download section of our website.

Should your application require a configuration that is not listed below, please contact **SECUCONTROL** at any of the addresses listed on the rear cover of this manual, or use the configurator on our homepage.

North America

SecuControl Inc.
2873 Duke Street
Alexandria, VA 22314
USA
Tel +1 703 838 7677
mail@secucontrol.com
www.secucontrol.com

Europe

SecuControl GmbH
Ascherslebener Str. 3
D-06333 Hettstedt
Germany
Tel +49 3476 550 022
info@secucontrol.com
www.secucontrol.com

South America

SecuBrasil Ltda
Rod José Carlos Daux, 8600
88050-001 Florianópolis SC
Brazil
Tel +55 (48) 3371 1670
comercial@secubrasil.com
www.secubrasil.com