

Safety Test Switch

Reference Handbook

STS-reference-en v.12 12 12 12



SecuControl

Copyright Notice

All information provided in this document is the property of **SECUCONTROL** .

SECUCONTROL grants its customers or potential customers the right to download, copy, store and print this document for the sole purpose of assisting them in the correct application of the products mentioned in this document.

All other uses of this document are expressly prohibited.

Intellectual Property Notice

This publication contains proprietary information under protection of the following (among others) patents: DE 10 2005 025 108, DE 10 2008 016 388, US 7,271,357 and US 7,884,597.

Contents Disclaimer

Although the information and recommendations in this document are presented in good faith and believed to be correct as of publication date, **SECUCONTROL** makes no representations as to the completeness or accuracy thereof. In no event shall **SECUCONTROL** be responsible for damages of any nature resulting from the use of or reliance upon the contents of this document.

Continuous Improvements

Products developed by **SECUCONTROL** are continuously improved. The information in this document may, therefore, be out of date.

Please make sure you have the latest release of this document before proceeding by checking its name and revision code. This information is printed on the front cover of this document, underneath the title. The latest release of this document can be downloaded from www.secucontrol.com/downloads. Alternatively, you may contact **SECUCONTROL** at any of the addresses provided on the rear cover of this document.

Contents

1	Introduction	1
	The Safety Test Switch	1
	Key Features	1
	Unpacking	1
	Part Number and Manufacturing Date Location	2
	Safety Symbols	2
	General Safety Instructions	2
2	Principle of Operation	3
	Closed Circuit	3
	Open Circuit	3
	Signal Injection	3
3	Application	5
	Schematic Symbols	5
	Typical Connection Schematic	6
4	Installation	7
	Panel Cutouts, Drilling Plans and Mounting	7
	Wiring	7
5	Operation	9
6	Technical Specifications	11
	Electrical	11
	Mechanical	12
	Dimensional Drawings	12
7	Models Available	13
	Number of Banana Jacks	13
8	Accessories	15
	Jumper Cable	15
	Current Measurement Probe	15
	Safety Test Switch 19" Rack Plates	16

Covers for 19" Safety Test Switch Rack Plate Cutouts	17
9 Spare Parts	19
Disconnect Pins	19
Dust Covers	19
Fitting Set	19
10 Ordering Information	21
Part Numbers	21
Available Configurations	21

1 Introduction

The Safety Test Switch

The Safety Test Switch (ST Switch) is a test switch for interfacing substation devices (protection relays, fault recorders, revenue meters, ...) to the voltage and current transformers and to other equipment on the system side of a power grid.

The ST Switch uses disconnect pins to isolate the substation devices from the system side equipment. Once isolated, secondary injection can be performed using banana jacks on the front side of the test switch.

Key Features

- Finger-safe Test Switch and Disconnect Pins increase safety during testing.
- Disconnect Pins are keyed to the corresponding parts of the Test Switch, preventing mistakes and errors during test.
- Visible open/closed contacts via status windows
- Extremely low internal resistance ($< 2 \text{ m}\Omega$) helps reduce heat inside cabinets and panels.
- Available in 10 or 14 pole configurations.

Unpacking

Unpack the product carefully and make sure that all pertinent parts like dust covers and screws are put aside so they will not be lost.

Check the contents against the packing list. If any of the contents listed are missing, please contact **SECUCONTROL** immediately (see contact information at the rear cover of this manual).

Examine the product for any shipping damage. If the product is damaged, notify the shipping company without delay. Only the consignee (the person or company receiving the unit) can file a claim against the carrier for shipping damage.

Part Number and Manufacturing Date Location

Part number and manufacturing date are stated on a label on the right side of the Test Switch.

Safety Symbols

The following symbols are located on different parts of the equipment and in this manual:



Paragraphs marked with this symbol contain information which, if not properly followed, may cause damage to the equipment and/or installation.



Paragraphs marked with this symbol contain information which, if not properly followed, may cause personal injury or even death.

General Safety Instructions

Installation and operation of the products described in this manual is only to be performed by personnel that has been trained or is knowledgeable in substation protection, automation and control.

This instruction manual is an integral part of the scope of delivery and provides basic instructions for installation and operation of the equipment here described. Shall additional information be needed, please contact **SECUCONTROL** at any of the addresses provided on the rear cover of this document.



Do not disassemble the Test Switch. Correct alignment of internal parts is critical in order to provide insulation and arch-avoidance.



The warranty will be void if the Test Switch is disassembled (or otherwise handled inappropriately). **SECUCONTROL** does not assume responsibility for any damages arising out of mishandling of our products, including test switches that have been disassembled by parties other than SecuControl.

2 Principle of Operation

Closed Circuit

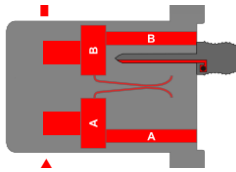

In the resting state the contacts of the ST Switch are closed. In this situation, the signals from the system side of the installation (side A) are connected to the measuring and protection devices (side B).

Open Circuit

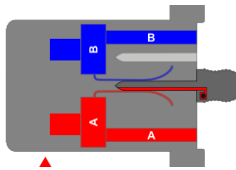

To open the Test Switch's contacts, the disconnect pins are moved from the parking position to the test position. In this situation, the devices on the B-side are insulated from the installation side.

Signal Injection

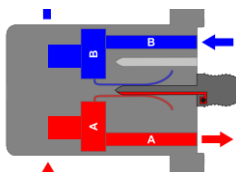

With the disconnect pins in the test position, signal injection can be performed using the banana jacks on the front side of the test switch.

3 Application

Schematic Symbols

Following symbols are suggested in order to represent the ST Switch in schematic diagrams.

Symbol	Description
	Signal, Voltage (single pole)
	Current (2-pole, 4-pole)

3. APPLICATION

Typical Connection Schematic

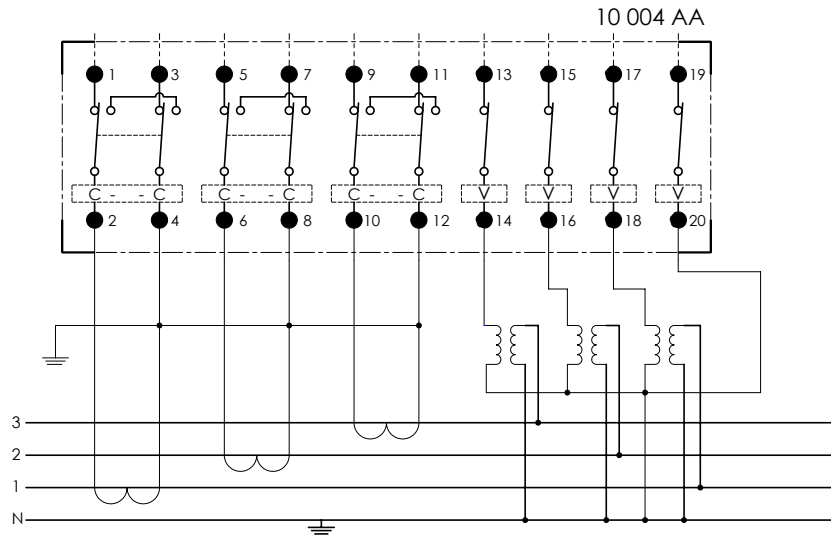

4 Installation

Panel Cutouts, Drilling Plans and Mounting

Use the provided M5x30 screws to fix the ST Switch onto the panel. The screws should be tightened using a 4 mm hex drive.

10-pole Models

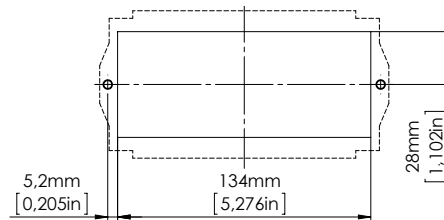

14-pole Models

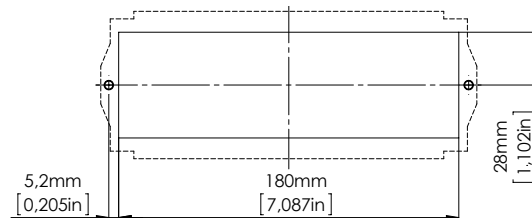

Wiring

Electrical connector sockets are located on the top and bottom of the ST Switch. Each of the connector sockets has a female thread which receives a screw in the back and accepts ring cable lugs, stripped wire or other crimp connectors. Alternatively, the connector sockets are available with a male thread which receives a nut in the back.

4. INSTALLATION

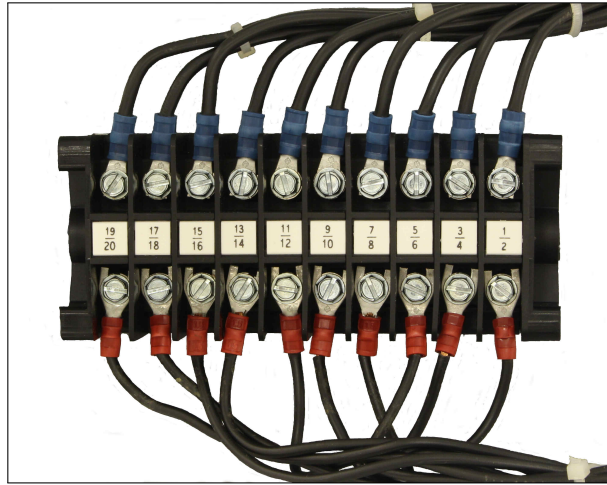

Recommended wire gauge is from 1.5 mm² (AWG 16) to 4 mm² (AWG 12).

CTs should be wired to the terminals provided for this purpose (in 2- or 4-pole combinations) to ensure automatic short circuiting upon insertion of the Disconnect Pins. The terminals designated for the connection of the CTs can be typically identified by the [C-C] or [C-C-C-C] labeling¹.



The panel equipments (protection relays, meters, fault recorders, etc) should be connected to the device side terminals indicated by the odd-numbers (1, 3, 5, 7, ...), or by the “b” suffix (1b, 2b, 3b, ...), depending on the model.



The protection equipments (current and voltage transformers, breaker, etc) should be connected to the system side terminals indicated by the even-numbers (2, 4, 6, 8, ...), or by the “a” suffix (1a, 2a, 3a, ...), depending on model.

¹Custom labeling may show other symbols or use other colors.

5 Operation

Handling of Disconnect Pins should be done using only its plastic part, since the fingers may be connected to live equipment either via the test switch or test equipment.



1. Remove the dust cover by sliding the cover up and then out.
2. Remove the ST Switch Disconnect Pins one-by-one from the parking position and insert them into the corresponding circuit's testing position.

There is no need to externally short-circuit the current transformers, since the 2- and 4- pole current Disconnect Pins have an integrated shorting bar which will automatically short circuit the corresponding circuits before opening it.

Notice that the dust cover can't be reattached to the test switch if any of the Disconnect Pins is in the testing position. This is intentional and provides a visual flag that testing is being performed.

3. For signal injection, connect the test set via the banana jacks on the ST Switch. This step is entirely based on your normal testing procedures, and should be planned and carefully executed by a trained technician.
4. Once you are ready to resume normal operation, remove the Disconnect Pins from the testing position and insert them back into the parking position.
5. Reattach the dust cover once all Disconnect Pins are returned to the parking position.

6 Technical Specifications

Electrical

Current Withstand	30 A continuously 500 A for 1 second
Maximum voltage	600 V
Contact resistance	$\leq 2 \text{ m}\Omega$
Dielectric Withstand	3.0 kV RMS for 1 minute between adjacent contact pairs and between any contact pair and other metal parts 2.0 kV RMS for 1 minute between open contacts when test pin is inserted
Voltage Impulse	3 positive and 3 negative impulses of 5 kV peak, 1.2/50 μs , 0.5 J between adjacent contact pairs and between all contact pairs and other metal parts
Temperature Range	-25 to +70 °C (-13 to +158°F), storage -25 to +55°C (-13 to +131°F), operation
UL94 Flammability Class	V-0
Enclosure Protection	IP20 without cover IP50 with dust cover attached

ST Switches have been classified as electromagnetically benign and are therefore excluded from the scope of the European Community Directive 2004/108/EC.

ST Switch meets or exceeds all requirements from ANSI / IEEE C37.90-2005.

6. TECHNICAL SPECIFICATIONS

Mechanical

# of poles	10	14
Weight (kg)	1,22	1,63
(lbs)	2,70	3,59

Dimensional Drawings

10-pole Models

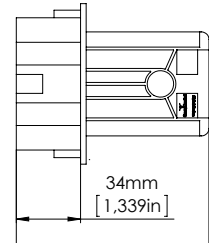
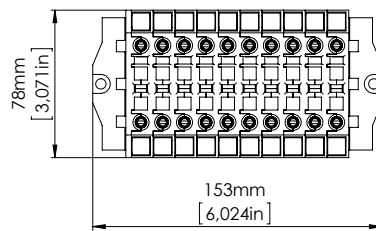

14-pole Models

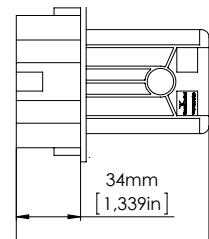
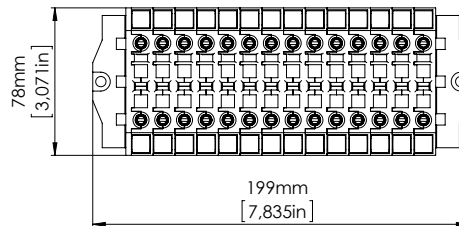

7 Models Available

Number of Banana Jacks

The Safety Test Switch provides banana jacks for easy and convenient test access. Two different models are available: Safety Test Switch_{IED} provides banana jacks on the device side ('B' side) only. The Safety Test Switch provides banana jacks on both, the system side ('A' side) and the device side ('B' side).

Model	Description
Safety Test Switch _{IED}	banana jacks on side B
Safety Test Switch	banana jacks on sides A & B

8 Accessories

Jumper Cable

This jumper cable allows the connection between 2 poles of the ST Switch. Both banana plugs of the jumper cable have a see-through retractable plastic shielding.

The adapter isn't necessary for shorting the current transformer circuits. The current transformer circuits will be shorted automatically by the internal shorting of the ST Switch.



Standard color: red (red = RD in the last 2 digits of the Order Code)

Other Colors:



Description	Order Code
Jumper cable for use with the ST Switch	FTJUM-RD

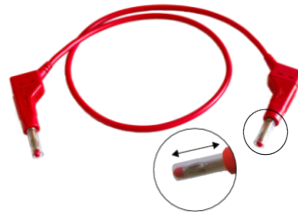

Current Measurement Probe

This special test probe allows for the connection of a current measurement device or a shunt. The AWG 13 (2.5 mm²) connection cable has a length of 118 inches (3 meters). The test probe is available with c-hook terminals or banana plugs.

The current measurement probe is a special tool that is built for current measurement purposes. It does NOT automatically short-circuit current transformer circuits upon insertion into the ST Switch. Instead, current circuits are opened and redirected via the attached wires once the probe is entered into the test block. The probe must always be correctly connected to a measurement instrument or a shunt before insertion into the ST Switch, to prevent the creation of an open current transformer circuit. The

8. ACCESSORIES



current measurement probe should be used by properly trained personnel only.

Description	Order Code
C-hook connection	UTPC1
Banana plug connection	UTPC2

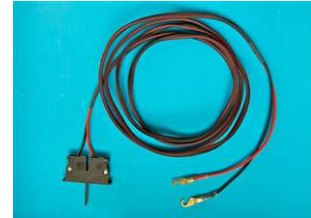

Safety Test Switch 19" Rack Plates

SECUCONTROL offers metal plates for installation of ST Switches in 19" racks that come painted in various colors and with various cutouts for ST Switches, in standard heights of 2U or 3U. 3U racks are available with centered and "low" cut-out positions. Please contact **SECUCONTROL**, if you require drawings or special customizations. The picture below shows an ANSI-grey #61 rack plate with three cutouts for 10-pole ST Switches.



F T x $\underbrace{\square \text{ U}}_{\text{height}}$ $\underbrace{\square \square}_{\text{config.}}$ $\underbrace{\square \square \square \square \square \square}_{\text{cutouts}}$ $\underbrace{\square \square}_{\text{color}}$

- height** Rack plates are available in 2U and 3U
- config.** A: standard 19" rack plates, 2mm thick with standard cutouts
B-Z: reserved for special configurations
- cutout** e.g. 14xx14 ; cutout for two 14-pole ST Switches
e.g. 14xxxx ; cutout for one 14-pole (left) ST Switch
e.g. 101010 ; cutout for three 10-pole ST Switches
max. modules per rack plate = 30
- color** These two digits define rack plate colors. Available options can be found in the table below:

Covers for 19" Safety Test Switch Rack Plate Cutouts

Color	Description
AG	ANSI-grey #61
PG	pebble grey RAL 7032
LG	light grey RAL 7035
BK	black

For all configurations with 3 cutouts and 30 modules (e.g. 3 x 10-pole cutouts), **SECUCONTROL** recommends special ST Switch fitting screws (M5x22). These screws should be mounted on the far left and the far right side of the rack plate, to prevent the tip of the screws from touching the mounting frame. Two special screws are included with every ST Switch rack plate with 3 cutouts\30 modules. Please use the order codes below for reordering.



Special Safety Test Switch Fitting Screws

Fitting set to fix the ST Switch in the rack plate cutout with 3 cutouts and 30 modules. The screw set contains two M5x22 hexagon socket head cap screws (4 mm)

Description	Order Code
Special fitting set M5	SCPFT



Covers for 19" Safety Test Switch Rack Plate Cutouts

Built to cover existing cutouts in rack plates for ST Switches, these metal covers are offered for different ST Switch cutout sizes.

Description	Order Code ANSI-grey #61	Order Code light grey	Order Code pebble grey	Order Code black
10-pole cover	FTBC10AG	FTBC08LG	FTBC08PG	FTBC08BK
14-pole cover	FTBC14AG	FTBC08LG	FTBC08PG	FTBC08BK

8. ACCESSORIES



9 Spare Parts

Disconnect Pins

# of poles	Labeling	Order Code
1	V	FTDP01RV
1	P	FTDP01RP
1	T	FTDP01RT
1	S	FTDP01RS
2	C-C	FTDP02WC
4	C-C-C-C	FTDP04WC

Dust Covers

# of poles	Order Code
10	FTDC10
14	FTDC14

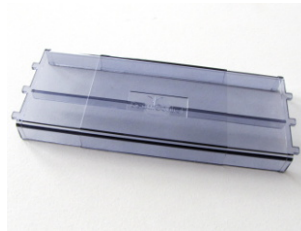

Fitting Set

Fitting set to fix the ST Switch in the panel cutout. The screw set contains two M5x30 hexagon socket head cap screws (4 mm) and two M5 nuts.

Description	Order Code
Fitting set M5	SCSFT



10 Ordering Information

Part Numbers

S T I \square \square \square \square \square \square \square \square ... Safety Test
opt. poles config. labeling Switch IED with banana
jacks on device
side

S T S \square \square \square \square \square \square \square \square ... Safety Test
opt. poles config. labeling Switch with banana
jacks on device side
and system side

with the following options:

- A ... screw connections and status windows with transparent lids
- C ... screw connections and no status windows
- X ... stud connections and no status windows
- Z ... stud connections and status windows with transparent lids

Available Configurations

A list of available Configurations can be found in the download section of our website.

Should your application require a configuration that is not listed below, please contact **SECUCONTROL** at any of the addresses listed on the rear cover of this manual, or use the configurator on our homepage.

North America

SecuControl Inc.
2873 Duke Street
Alexandria, VA 22314
USA
Tel +1 703 838 7677
mail@secucontrol.com
www.secucontrol.com

Europe

SecuControl GmbH
Ascherslebener Str. 3
D-06333 Hettstedt
Germany
Tel +49 3476 550 022
info@secucontrol.com
www.secucontrol.com

South America

SecuBrasil Ltda
Rod José Carlos Daux, 8600
88050-001 Florianópolis SC
Brazil
Tel +55 (48) 3371 1670
comercial@secubrasil.com
www.secubrasil.com